



## Ball Valve

# 1PC BALL VALVE (QF101)



### FEATURES

- ◆ 1000PSI/PN63
- ◆ Reduce Port
- ◆ Investment Casting
- ◆ Blow-out proof Stem
- ◆ Casting Approved AD2000-W0
- ◆ PED97/23/EC/CE0035)Approved
- ◆ W.P: 1/4"-2" 1000psi 2 1/2"-4" 800psi
- ◆ Thread: ASME B1.20.1 BS21.DIN2999/259, ISO228-1, JIS B 0203, ISO7/1
- ◆ Inspection Testing: API598, EN12266

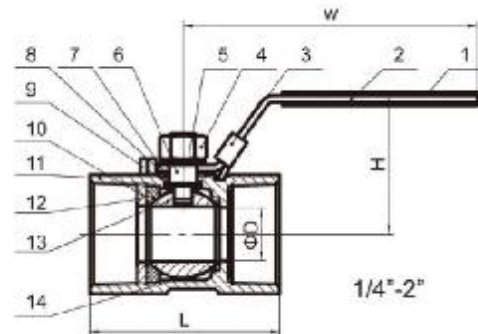
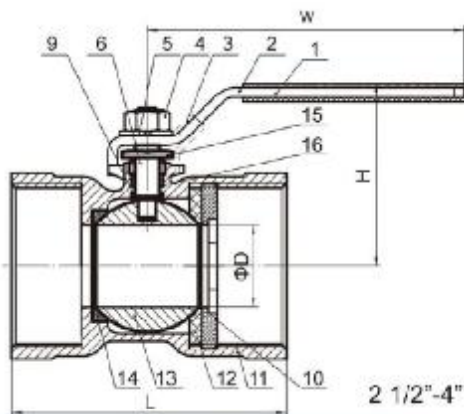

ITEM	DESIGNATION	MATERIAL
1	HANDLE SLEEVE	PVC
2	HANDLE	304
3	LOCKING	304
4	STEM NUT	304
5	SPRING WASHER	304
6	STEM	304/316
7	PACKING RING	304
8	STEM PACKING	PTFE
9	THRUST WASHER	PTFE
10	CAP	CF8/CF8M
11	BODY	CF8/CF8M
12	BALL SEAT	RPTFE
13	BALL	304/316
14	BALL SEAT	PTFE
15	GLAND NUT	304
16	STEM PACKING	PTFE

SIZE	ΦD	L	H	W	S	
1/4"	5	39	31	65	17	HEX
3/8"	6.8	44	36	85	21	
1/2"	9.2	56.5	41	95	25	
3/4"	12.5	59	44	95	32	
1"	15	71	48	111	38	
1-1/4"	20	78	54	111	49	
1-1/2"	25	83	65	135	53	OCT
2"	32	100	72	135	65	
2-1/2"	38	120	80	154	83	
3"	50	140	100	191	98	
4"	64	170	129	246	127	